

I-Beam Frame Design

Delta

27LPD



7-Ton LOW PRO Dump Trailer

I-Beam Frame, Bumper Pull



DELTA TRAILERS • 1-800-556-2283 • www.deltatrailers.com



27LPD

7-TON LOW-PRO DUMP TRAILER I-BEAM FRAME, BUMPER PULL

S P E C I F I C A T I O N S

| | | | |
|-------------------------|--|------------------------|--|
| G.V.W.R. | 14,000# | HYDRAULIC LIFT | Self-Contained Electric/Hydraulic Scissor Lift |
| COUPLER | 2 5/16" Coupler on Leveler Track | HYDRAULIC PUMP | Front Mount Pump & Battery Inside Toolbox |
| AXLES | Tandem 7,000# Single Wheel | CONTROL | Magnetic Control Unit |
| SUSPENSION | Multi-Leaf Slipper Spring with Equalizer | DUMP BED SIDES | 24" High, 12 Gauge Smooth Steel |
| BRAKES | Electric Brakes on All Axles | REAR GATE/DOOR | Combination Dump/Swing Gate with Cam Latches |
| TIRE | ST235/80R16 (10 ply) | LOADING RAMPS | 2 - 6 ft. Loading Ramps |
| WHEEL | 16 x 6, 8-bolt Steel | LIGHTS | All LED Stop, Tail, Turn and Clearance |
| FRAME | 8" I-Beam | ELECTRIC PLUG | 7-Way RV Style |
| TONGUE | 8" I-Beam | PREP | 3-Step Acid Washed with Phosphorus Solution |
| CROSSMEMBERS | 3" Channel | PRIMER | Rust Resistant Epoxy Primer |
| BED CROSSMEMBERS | 3" Channel on 12" Centers | PAINT | High Solid Urethane |
| SAFETY CHAINS | Heavy Duty with Safety Latch Hooks | PINSTRIPES | Painted Pinstripes |
| JACK | 12,000# Spring Loaded Drop Leg Jack | WIDTH | 84" Wide (approx.) |
| BED TIE DOWNS | 4-Heavy Duty D-Rings | FLOOR HEIGHT | Approx. 22" |
| FLOOR | 10 Gauge Smooth Steel | STORAGE | Front Mounted Toolbox with Lid (in A-Frame) |
| FENDERS | Steel Diamondplate | WIRING | Front Molded Harness |
| DUMP ANGLE | 45 Degree Dump Angle (approx) | REFLECTIVE TAPE | Required D.O.T. Reflective Taping |
| TARP/MOUNT | Tarp Mount is Standard, Tarp Optional | SAFETY | Emergency Breakaway Switch & Battery Backup |

All specifications subject to change without notice.

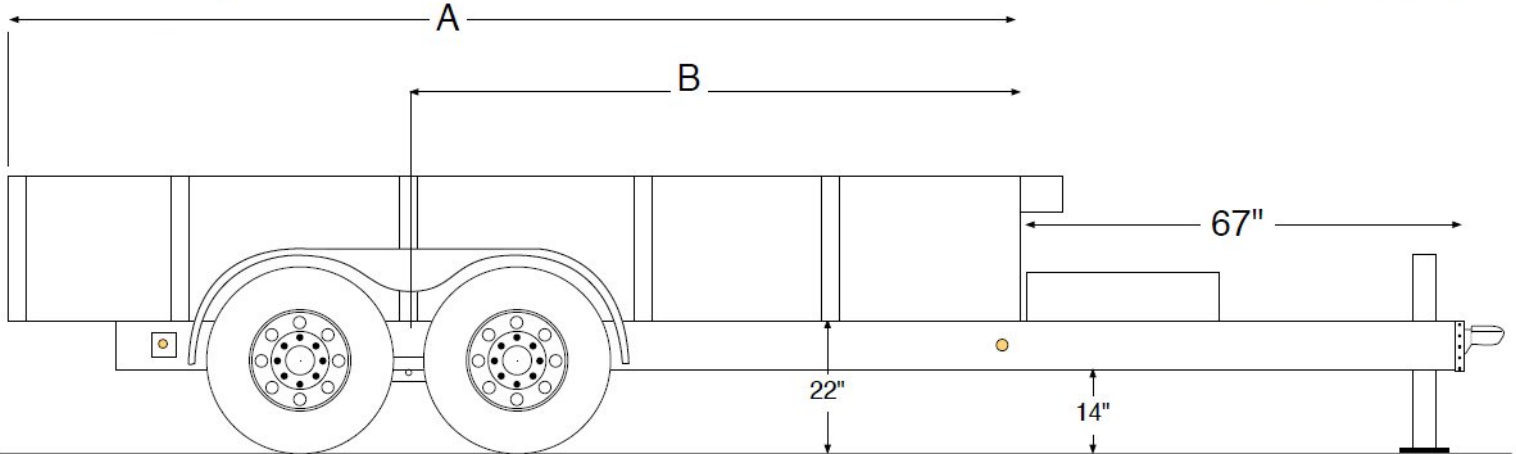

M E A S U R E M E N T S

| MODEL | LENGTH | CAPACITY | A | B |
|----------|--------|------------------|------|------|
| 27NBD-12 | 12' | 9.1 cubic yards | 144" | 81" |
| 27NBD-14 | 14' | 10.6 cubic yards | 168" | 102" |
| 27NBD-16 | 16' | 12.1 cubic yards | 192" | 108" |

O P T I O N S

- 3/16" Floor Upgrade (crossmembers on 12" OC)
- Debris Tarp
- Spare (Complete Tire & Wheel)
- Shrinkwrap Electrical Connections
- Upgrade to 14-ply radial tires