

<b>G.V.W.R</b>	14,000#	<b>TILT-SYSTEM</b>	Two-way Hydraulic Dampening System
<b>COUPLER</b>	2 5/16" Bulldog Adjustable Gooseneck Coupler	<b>LOADING AREA</b>	Split Diamondplate loading edge
<b>AXLES</b>	Tandem 7,000# Single Wheel	<b>LIGHTS</b>	All LED Stop, Tail, Turn and Clearance
<b>SUSPENSION</b>	Dexter Torflex Axles (independent)	<b>ELECTRIC PLUG</b>	7-Way RV Style
<b>BRAKES</b>	Electric brakes on all axles	<b>PREP</b>	3-Step Acid Washed with Phosphorus Solution
<b>TIRE</b>	ST235/80R16 (10 ply)	<b>PRIMER</b>	Rust Resistant Epoxy Primer
<b>WHEEL</b>	16 x 6, 8-bolt	<b>PAINT</b>	High Solid Urethane
<b>FRAME</b>	5" Channel with 5" Channel Stacked Support	<b>PINSTRIPES</b>	Painted Pinstripes
<b>GOOSENECK</b>	8" Channel	<b>WIDTH</b>	83" wide (approx)
<b>CROSSMEMBERS</b>	3" Channel on 16" centers	<b>DECK HEIGHT</b>	Approx. 27" standard
<b>SAFETY CHAINS</b>	Heavy Duty with Safety Latch Hooks	<b>STORAGE</b>	Chain Basket between uprights
<b>JACK</b>	Single 12,000# Spring Loaded Drop Leg Jack	<b>WIRING</b>	Front Mount in conduit
<b>TOP FRAME</b>	2" x 5" Tubing with Rub Rails & Stake Pockets	<b>REFLECTIVE TAPE</b>	Required D.O.T. Reflective Taping
<b>FLOOR</b>	2" Pressure Treated Pine	<b>SAFETY</b>	Emergency Breakaway switch & battery backup
<b>FENDERS</b>	Diamondplate Teardrop with full backplate		
All specifications subject to change without notice.			

### Measurements

20' model shown (4 + 16)

Length	Tilt Deck	Front Deck	A	B
18	16'	2'	216	112"
20	16'	4'	240	136"
22	16'	6'	264	160"
24	16'	8'	288	184"

All measurements are approximate

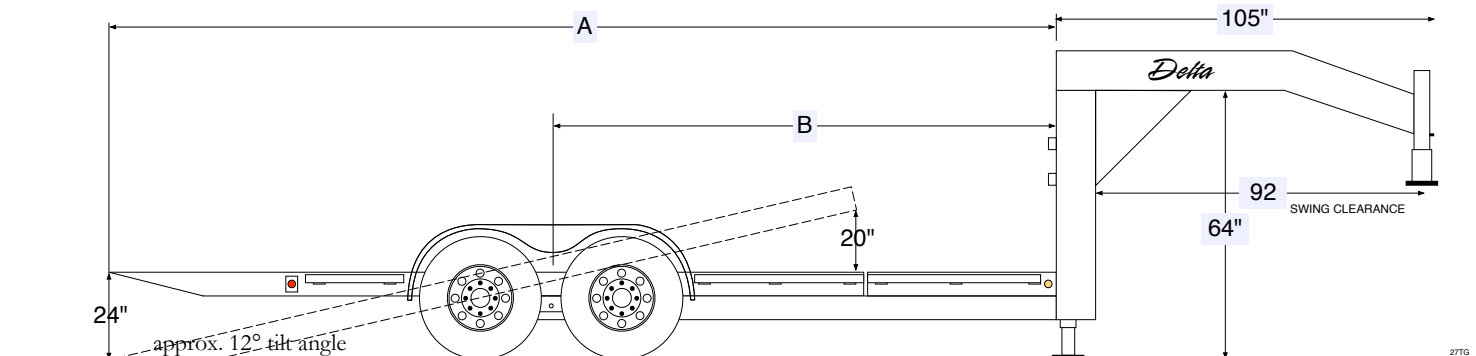

### SUGGESTED RETAIL PRICE

Gooseneck

Model	Length	Fixed Deck	Tilt-Deck	MSRP
27TG-18	18'	2'	16'	\$7,800
27TG-20	20'	4'	16'	\$8,220
27TG-22	22'	6'	16'	\$8,641
27TG-24	24'	8'	16'	\$9,061

### 27TB OPTIONS PRICING

Lid for Chain Basket	\$80	Removable Diamondplate Fenders	\$435
Extra Spring Loaded Jack (Dual Jacks)	\$235	D-Rings (ea.)	\$26
2-Speed Jack System (includes 2nd Jack)	\$426	Spare Wheel	\$85
Metal Floor (3/16" Diamondplate with crossmembers on 12" centers)	\$79/ft.	Spare (Complete Tire & Wheel)	\$252
Shrinkwrap Electrical Connections	\$86	8K axle upgrade (includes frame reinforcement)	\$2,593
Full Power Up/Down Option (Hydraulic pump system)	\$919	add 3rd 7K axle (includes frame reinforcement & tri-axle fenders)	\$2,180
Blackwood (rubber infused lumber) excellent traction	\$48/ft.		