

27TB

Tandem Axle Tilt-Bed

G.V.W.R	14,000#	TILT-SYSTEM	Two-way Hydraulic Dampening System
COUPLER	2 5/16" Bulldog Coupler on Leveler Track	LOADING AREA	Split Diamondplate loading edge
AXLES	Tandem 7,000# Single Wheel	LIGHTS	All LED Stop, Tail, Turn and Clearance
SUSPENSION	Dexter Torflex Axles (independent)	ELECTRIC PLUG	7-Way RV Style
BRAKES	Electric brakes on all axles	PREP	3-Step Acid Washed with Phosphorus Solution
TIRE	ST235/80R16 (10 ply)	PRIMER	Rust Resistant Epoxy Primer
WHEEL	16 x 6, 8-bolt	PAINT	High Solid Urethane
FRAME	5" Channel	PINSTRIPES	Painted Pinstripes
TOUNGE	5" Channel	WIDTH	83" wide (approx)
CROSSMEMBERS	3" Channel on 16" centers	DECK HEIGHT	Approx. 27"
SAFETY CHAINS	Heavy Duty with Safety Latch Hooks	STORAGE	Storage Area in A-Frame (Expanded Metal)
JACK	Single 12,000# Spring Loaded Drop Leg Jack	WIRING	Front Mount in conduit
TOP FRAME	2" x 5" Tubing with Rub Rails & Stake Pockets	REFLECTIVE TAPE	Required D.O.T. Reflective Taping
FLOOR	2" Pressure Treated Pine	SAFETY	Emergency Breakaway switch & battery backup
FENDERS	Diamondplate Teardrop with full backplate		
All specifications subject to change without notice.			

Measurements

20' model shown (4 + 16)

Length	Tilt Deck	Front Deck	A	B
18	16'	2'	216	112"
20	16'	4'	240	136"
22	16'	6'	264	160"
24	16'	8'	288	184"

All measurements are approximate

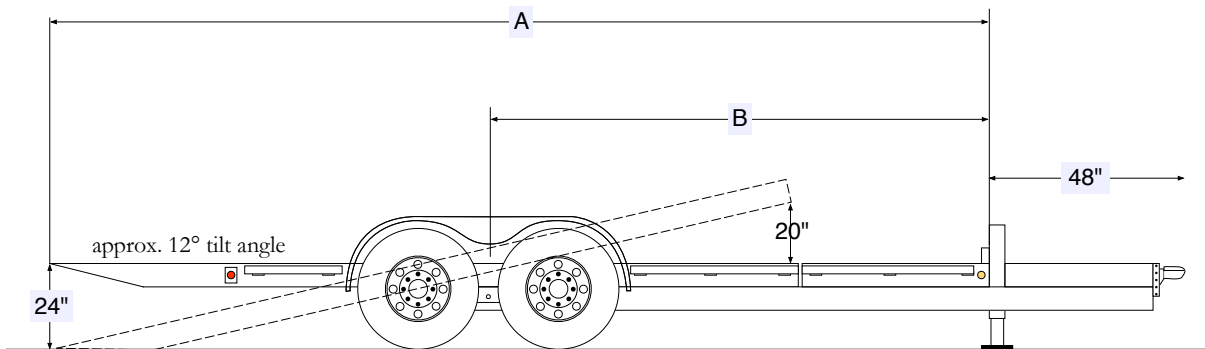

SUGGESTED RETAIL PRICE

Bumper Pull

Model	Length	Fixed Deck	Tilt-Deck	MSRP
27TB-18	18'	2'	16'	\$7,052
27TB-20	20'	4'	16'	\$7,471
27TB-22	22'	6'	16'	\$7,894
27TB-24	24'	8'	16'	\$8,312

27TB OPTIONS PRICING

Lid for Chain Basket	\$80	Removable Diamondplate Fenders	\$435
Extra Spring Loaded Jack (Dual Jacks)	\$235	D-Rings (ea.)	\$26
2-Speed Jack System (includes 2nd Jack)	\$426	Spare Wheel	\$85
Metal Floor (3/16" Diamondplate with crossmembers on 12" centers)	\$79/ft.	Spare (Complete Tire & Wheel)	\$252
Shrinkwrap Electrical Connections	\$86	8K axle upgrade (includes frame reinforcement)	\$2,473
Full Power Up/Down Option (Hydraulic pump system)	\$919	add 3rd 7K axle (includes frame reinforcement & tri-axle fenders)	\$2,180
Blackwood (rubber infused lumber) excellent traction	\$48/ft.		