

<b>G.V.W.R</b>	23,400#	<b>ELECTRIC PLUG</b>	7-Way RV Style
<b>COUPLER</b>	2 5/16" E-Z Adjustable Coupler	<b>PREP</b>	3-Step Acid Washed with Phosphorus Solution
<b>AXLES</b>	Tandem 10,000# Dual Wheel (Oil-Bath)	<b>PRIMER</b>	Rust Resistant Epoxy Primer
<b>SUSPENSION</b>	Multi-leaf Slipper Spring with Equalizer	<b>PAINT</b>	High Solid Urethane
<b>TIRE</b>	ST235/80R16 (10 ply)	<b>PINSTRIPES</b>	Painted Pinstripes
<b>WHEEL</b>	16 x 6 Dual 8-bolt	<b>OVERALL WIDTH</b>	102" wide (approx)
<b>FRAME</b>	12", (19 lbs./ft.)	<b>DECK HEIGHT</b>	Approx. 38" standard
<b>NECK</b>	12" I-Beam	<b>BRAKES</b>	Electric brakes on all axles
<b>CROSSMEMBERS</b>	3" Channel on 16" centers	<b>STEPS</b>	Access Step on driver's side
<b>SAFETY CHAINS</b>	3/8" Heavy Duty with Safety Latch Hooks	<b>STORAGE</b>	Chain Basket between uprights
<b>JACK</b>	12,000# Spring Loaded Drop Leg Jack	<b>WIRING</b>	Front Mount in conduit
<b>SIDE RAILS</b>	5" Angle Iron with Rub Rails & Stake Pockets	<b>REFLECTIVE TAPE</b>	Required D.O.T. Reflective Taping
<b>STAKE POCKETS</b>	Formed Stake Pockets on 24" centers	<b>SAFETY</b>	Emergency Breakaway switch & battery backup
<b>FLOOR</b>	2" Pressure Treated Pine		
<b>LIGHTS</b>	All LED Stop, Tail, Turn and Clearance		All specifications subject to change without notice.

### Measurements

26' model shown (6 + 20)

Length	Tilt Deck	Front Deck	A	B	C
26	20'	6'	312	177"	38"
30	20'	10'	360	237"	38"

All measurements are approximate

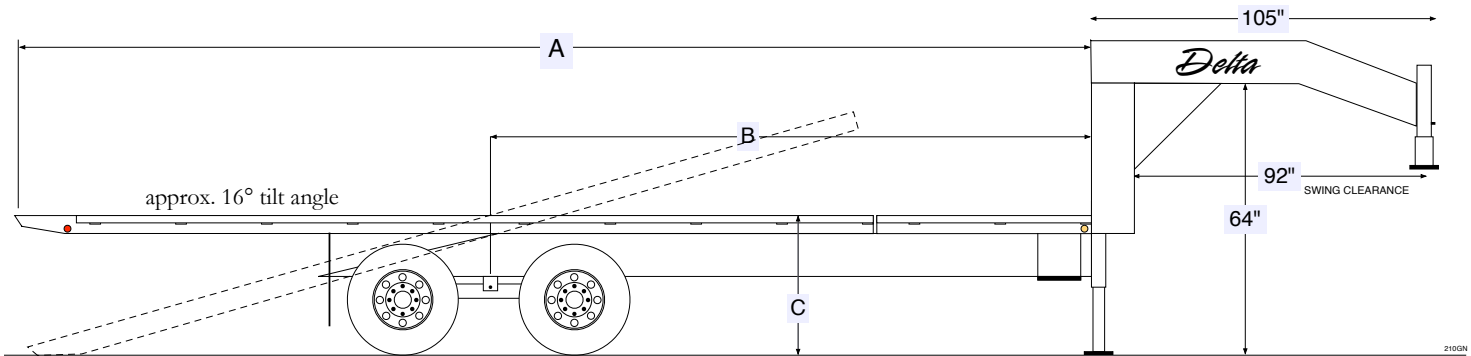

### SUGGESTED RETAIL PRICE

Model	Length	MSRP
210GT-26	26' (6 ft. Fixed Deck + 20 ft. Tilt Deck)	\$13,818
210GT-30	30' (10 ft. Fixed Deck + 20 ft. Tilt Deck)	\$14,608

### 210GT OPTIONS PRICING

Disc Brakes (includes 10K HD upgrade) - Must add Elec./Hyd. Brakes	\$1,510	Torque Tube (helps minimize trailer twisting)	\$41/ft.
Electric over Hydraulic Brakes	\$2,000	Metal Floor (3/16" Diamondplate with crossmembers on 12" cen-	\$79/ft.
Dexter HD Adjustable Suspension (similar to Hutch)	\$600	Spare Wheel	\$105
Lid for Chain Basket	\$79	Spare (Complete Tire & Wheel)	\$279
Side Mount Toolbox with lid	\$345	Upgrade 10K Heavy Duty axles	\$2,891
Extra Spring Loaded Jack (Dual Jacks)	\$235	Upgrade 12K axles	\$2,981
2-Speed Jack System (includes 2nd Jack)	\$426	Upgrade to 12", 22 lbs. I-Beam	\$17/ft.
Pipe Spools (between Stake Pockets)	\$130	Upgrade to 14-ply radial tires	\$156/tire
Full Power up/Down Hydraulic System (scissor hoist)	\$3,683	Blackwood (rubber infused lumber) excellent traction	\$48/ft.